



F120-H830.02 S9W2V

Pneumatic taper change

Item no. **10408010**

HF-Spindle for high-speed milling, -grinding, -drilling, -engraving

Bearings

| | |
|---------------------------|------------------|
| Hybrid ball bearing (pcs) | 4 |
| Lifetime lubricated | maintenance free |

Motor

| | |
|--|---|
| Motor technology | 3-phase asynchronous drive (no brushes or sensors) |
| Frequency | 1.000 Hz |
| Motor poles (pairs) | 2 |
| Rated rotation speed | 30.000 rpm |
| Acceleration/braking value Per second | 10 000 rpm (other values by consultation) |

Power values

Liquid cooled

| | Pmax./5s | S6-60% | S1-100% | |
|-------------|----------|--------|---------|------|
| Rated power | 36 | 19 | 16,6 | [kW] |
| Torque | | | | [Nm] |
| Voltage | 400 | 400 | 400 | [V] |
| Current | | | 37 | [A] |

F120-H830.02 S9W2V

Pneumatic taper change
Item no. **10408010**

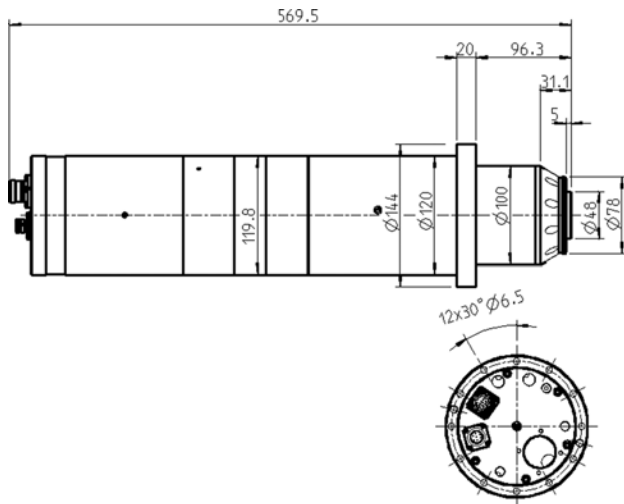

Dimensions

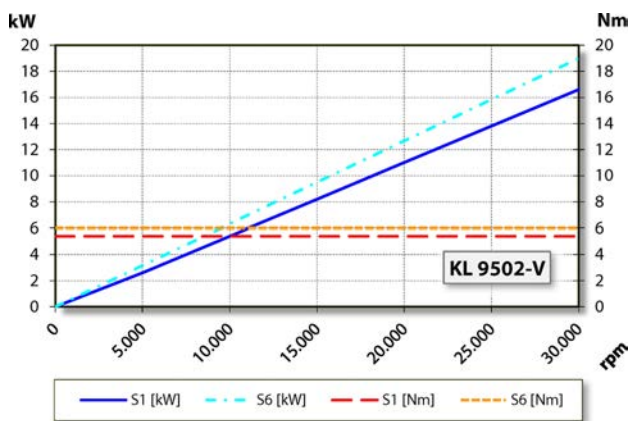

Performance Diagram
Liquid cooled

Measurement of power is funded by in-house testing.

Characteristics

| | |
|--|---|
| Speed sensor | Vector control |
| Toothed wheel | Teeth = 256 Module = 0,3 |
| Motor protection | PTC 145°C |
| Housing | Stainless steel |
| Housing diameter | 120 mm |
| Flange diameter | 144 mm |
| Pitch circle | dia. 132 mm (12 x Ø 6,5) for screws: M6 |
| Cooling | Liquid cooled |
| Ambient temperature | + 10°C ... + 45°C |
| Sealing air | |
| Protection category (sealing air turned on) | IP54 |
| Taper cleaning | |
| Tool change | Pneumatic taper change |
| Tool Holder | HSK-E 50 |
| Tool change monitoring | inductive |
| 3 positions | clamped, unclamped, ejected |
| Clamping range up to | 20 mm |
| Clockwise and anticlockwise | |
| Coupler plug | 6-pin (SpeedTEC) (motor phases) 12-pin (ECTA 133) + 17-pin (sensors) |
| Weight | ~ 25,5 kg |
| Inner taper run out | < 1 µ |
| Axial run-out | < 1 µ |