



F120-H824.11 S11RW2V

Pneumatic taper change

Item no. **10408017**

HF-Spindle for high-speed milling, -grinding, -drilling, -engraving

Bearings

Hybrid ball bearing (pcs)	4
Lifetime lubricated	maintenance free

Motor

Motor technology	3-phase asynchronous drive (no brushes or sensors)
Frequency	800 Hz
Motor poles (pairs)	2
Rated rotation speed	24.000 rpm
Acceleration/braking value Per second	10 000 rpm (other values by consultation)

Power values

Liquid cooled

	Pmax./5s	S6-60%	S1-100%	
Rated power	26	20	18	[kW]
Torque	21,4	15,5	13,6	[Nm]
Voltage	380	380	380	[V]
Current	55	43,8	39,7	[A]

F120-H824.11 S11RW2V

Pneumatic taper change

Item no. **10408017**

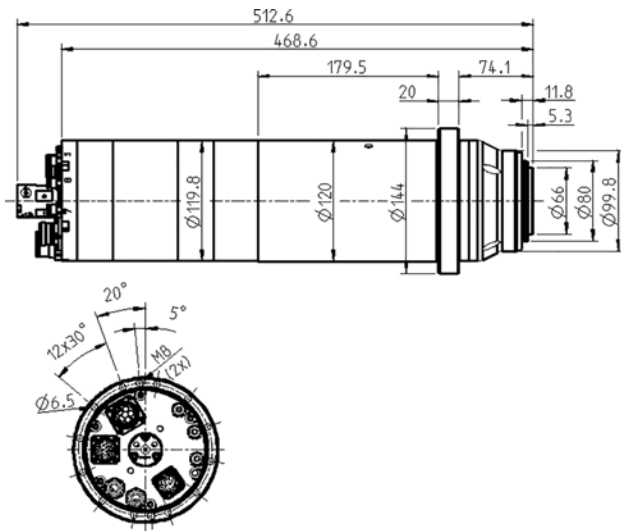

Dimensions

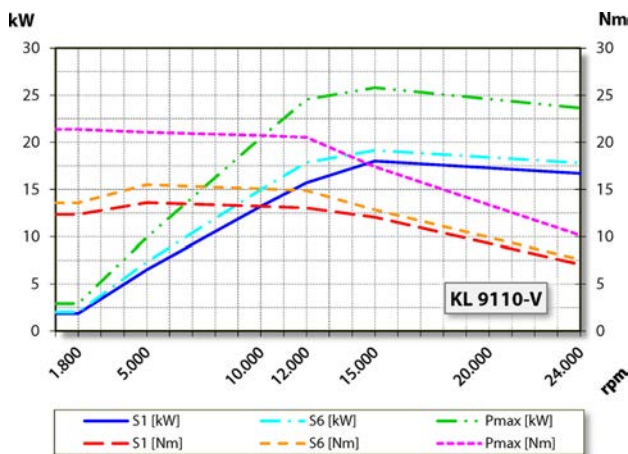

Performance Diagram

Liquid cooled

Measurement of power is funded by in-house testing.

Characteristics

Speed sensor	Vector control
Toothed wheel	Teeth = 256 Module = 0,3
Motor protection	PTC 130°C Pt1000
Housing	Stainless steel
Housing diameter	120 mm
Flange diameter	144 mm
Pitch circle	dia. 132 mm (12 x $\varnothing 6,5$) for screws: M6
Cooling	Liquid cooled
Ambient temperature	+ 10°C ... + 45°C
Sealing air	
Protection category (sealing air turned on)	IP54
Taper cleaning	
Internal coolant supply	
Internal coolant supply	< 80 bar < 10 l/min
Tool change	Pneumatic taper change
Tool Holder	HSK-E 50 + HSK-F 63
Tool change monitoring	inductive
3 positions	clamped, unclamped, ejected
Clamping range up to	20 mm
Clockwise and anticlockwise	
Coupler plug	5-pin (ECTA 133) (motor phases) 12-pin (ECTA 133) + 17-pin (sensors)
Weight	~ 27 kg
Inner taper run out	< 1 μ
Axial run-out	< 1 μ