

Chopper 2300-40 HSK S19

Pneumatic taper change

Item no. **11503007**

HF-Spindle for high-speed milling, -grinding, -drilling, -engraving

Bearings

Hybrid ball bearing (pcs)	2
Lifetime lubricated	maintenance free

Motor

Motor technology	3-phase asynchronous drive (no brushes or sensors)
Frequency	667 Hz
Motor poles (pairs)	1
Rated rotation speed	40.000 rpm
Acceleration/braking value Per second	10 000 rpm (other values by consultation)

Power values

Liquid cooled

	Pmax./5s	S6-60%	S1-100%	
Rated power	3,5	2,6	2,3	[kW]
Torque	1,24	0,96	0,82	[Nm]
Voltage	200	200	200	[V]
Current	14	10	9,5	[A]

Chopper 2300-40 HSK S19

Pneumatic taper change
Item no. 11503007

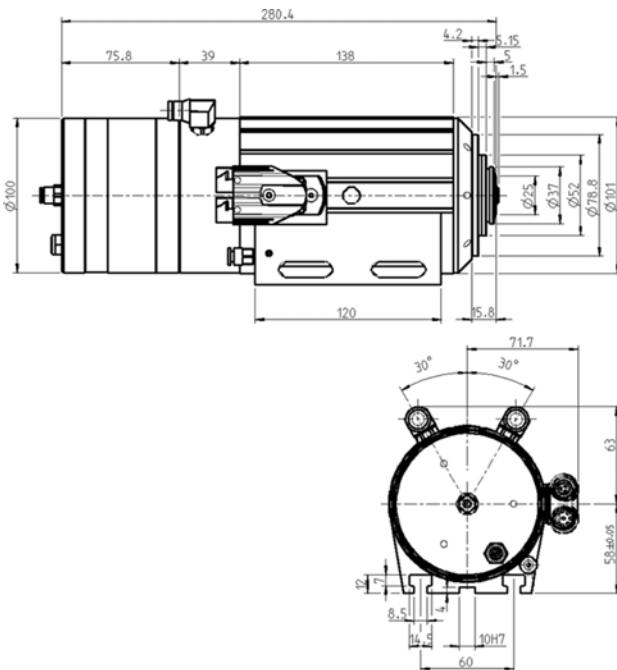

Dimensions

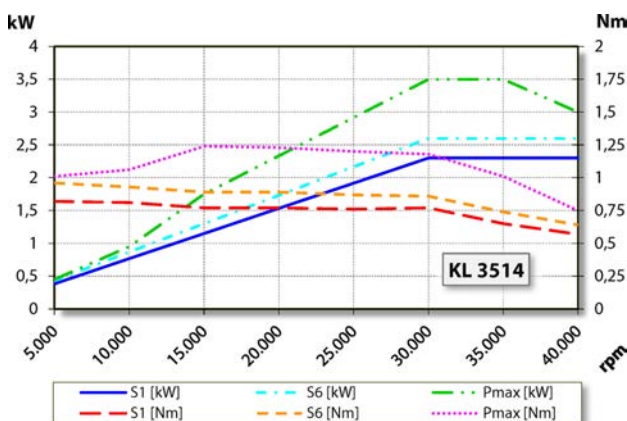

Performance Diagram

Liquid cooled

Measurement of power is funded by in-house testing.

Characteristics

Speed sensor	Differential magneto resistor (TTL) Number of signals = 6
Motor protection	PTC 130°C
Housing	Aluminium
Housing diameter	100 mm
T-slots	DIN 650-8
Spindle holder integrated	
Cooling	Liquid cooled
Ambient temperature	+ 10°C ... + 45°C
Sealing air	
Protection category (sealing air turned on)	IP54
Taper cleaning	
Tool change	Pneumatic taper change
Tool Holder	HSK-E 25
Tool change monitoring	inductive
1 position	clamped
Clamping range up to	10 mm
Clockwise and anticlockwise	
Coupler plug	Y-TEC 9-pin (motor phases) 12-pin (sensors)
Weight	~ 7 kg
Inner taper run out	< 2 µ
Axial run-out	< 2 µ